



US 20150017038A1

(19) **United States**  
(12) **Patent Application Publication**  
**Kheradvar et al.**

(10) **Pub. No.: US 2015/0017038 A1**  
(43) **Pub. Date: Jan. 15, 2015**

(54) **HELICALLY ACTUATED  
POSITIVE-DISPLACEMENT PUMP AND  
METHOD**

tinuation of application No. 11/389,525, filed on Mar. 24, 2006, now Pat. No. 7,883,325.

(60) Provisional application No. 60/665,462, filed on Mar. 25, 2005.

(71) Applicants: **Arash Kheradvar**, Irvine, CA (US);  
**Morteza Gharib**, Altadena, CA (US);  
**Anna Hickerson**, Altadena, CA (US)

**Publication Classification**

(72) Inventors: **Arash Kheradvar**, Irvine, CA (US);  
**Morteza Gharib**, Altadena, CA (US);  
**Anna Hickerson**, Altadena, CA (US)

(51) **Int. Cl.**  
**F04B 43/08** (2006.01)  
(52) **U.S. Cl.**  
CPC ..... **F04B 43/086** (2013.01)  
USPC ..... **417/478**

(73) Assignee: **CALIFORNIA INSTITUTE OF  
TECHNOLOGY**, Pasadena, CA (US)

(57) **ABSTRACT**

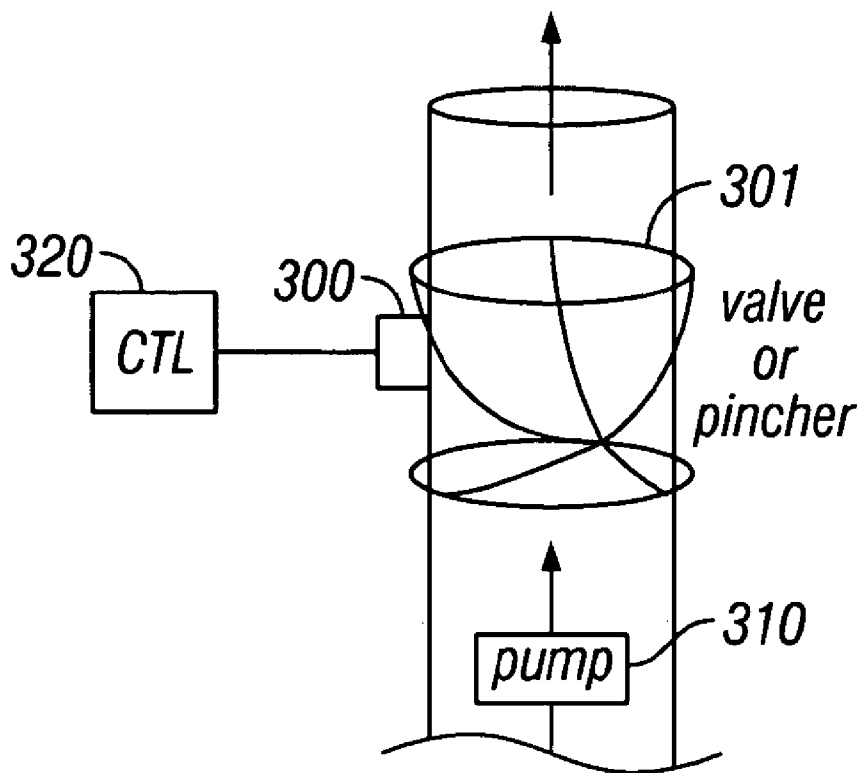
(21) Appl. No.: **14/329,778**

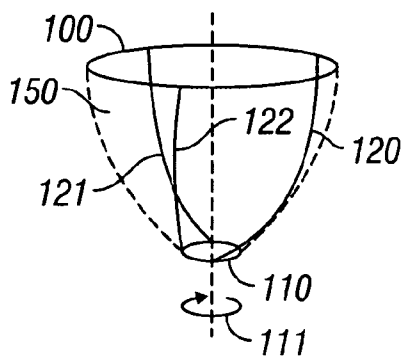
First and second structures are connected by helical fibers. The orientation between the first and second structures are changed, and by doing so, the positions of the helical fibers are correspondingly changed. The position of change of the helical fibers can be used for a pumping effect, or to change some other fluidic characteristics. One other fluidic characteristic, for example, may use the movement of the helical fibers as a valve.

(22) Filed: **Jul. 11, 2014**

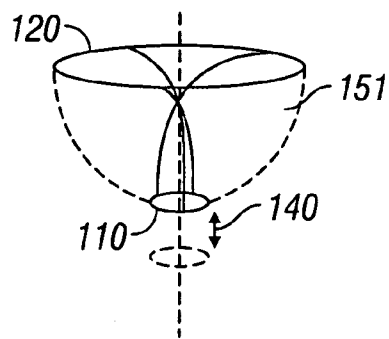
**Related U.S. Application Data**

(63) Continuation of application No. 13/022,562, filed on Feb. 7, 2011, now Pat. No. 8,794,937, which is a con-

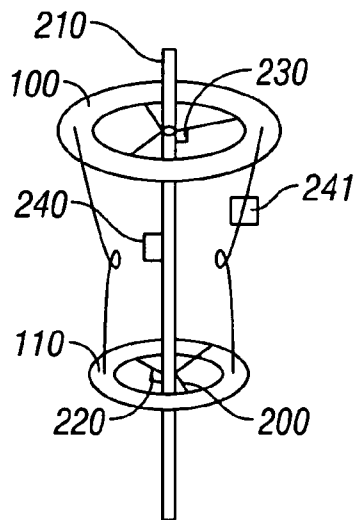




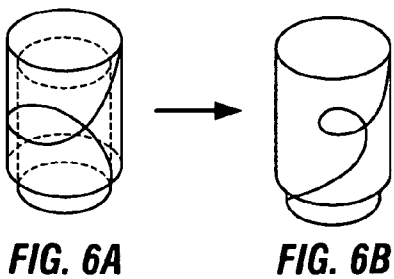
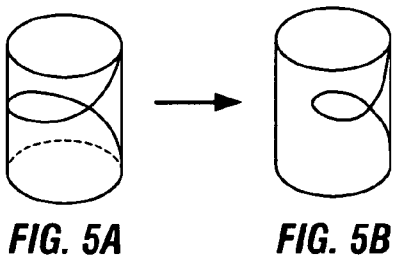
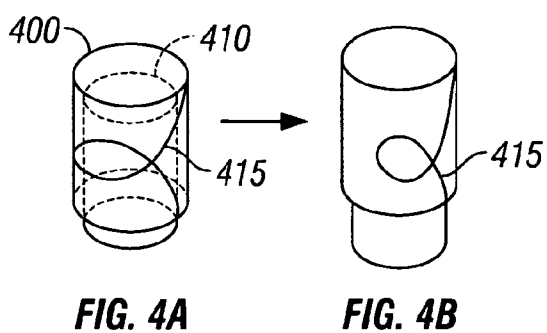
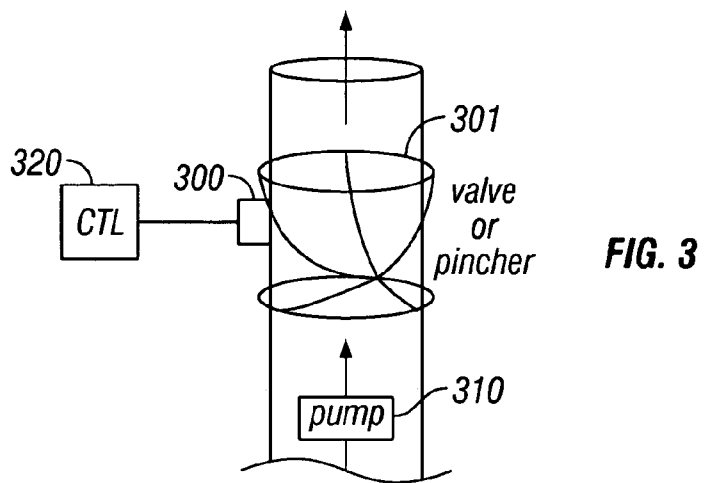
**FIG. 1A**



**FIG. 1B**



**FIG. 2**



**HELICALLY ACTUATED  
POSITIVE-DISPLACEMENT PUMP AND  
METHOD**

CROSS-REFERENCE TO RELATED  
APPLICATIONS

[0001] This application is a continuation of U.S. patent application Ser. No. 13/022,562, filed Feb. 7, 2011, which is a continuation of U.S. patent application Ser. No. 11/389,525, filed Mar. 24, 2006, which claims priority to Provisional Patent Appl. No. 60/665,462, filed Mar. 25, 2005, all of which are incorporated by reference herein in their entireties and for all purposes.

BACKGROUND

[0002] Certain applications require pumping of fluids. One common way of pumping such fluids is by using rotating blades which cut through the fluid and cause a flow. Other techniques for pumping fluids are known including peristaltic pumps, as well as an impedance pump as described in U.S. Pat. No. 6,679,687.

[0003] Certain kinds of fluids, such as blood or certain kinds of polymers, cannot be easily pumped using rotating blades. In the case of blood, the blades may harm some of the living cells within the fluid.

SUMMARY

[0004] The present application teaches a technique of pumping the fluids using helically and/or spirally displaceable materials. In an embodiment, the pump is caused to operate by moving at least element relative to another, to correspondingly move the displaceable materials. Another embodiment uses contraction of the helical fibers to cause a constriction which can be used as a valving effect.

BRIEF DESCRIPTION OF THE DRAWINGS

[0005] FIGS. 1A and 1B show a schematic diagram of a pumping action;

[0006] FIG. 2 illustrates how the rings can be rotated relative to one another;

[0007] FIG. 3 illustrates how the device can be used as a valve or pincher;

[0008] FIGS. 4a-6b illustrate different embodiments which enable constriction of the area in the valve/pincher operation.

DETAILED DESCRIPTION

[0009] The general structure and techniques, and more specific embodiments which can be used to effect different ways of carrying out the more general goals, are described herein.

[0010] An embodiment of a pumping mechanism is shown in FIGS. 1A and 1B. The pumping mechanism as shown is a positive displacement pumping mechanism. Helical or spiral materials, e.g., fibers, wires or bands, are used to cause the movement. In the embodiment, the helical fibers are connected to rotatable structures, e.g., rings which have either the same or different diameters.

[0011] FIG. 1a shows a first ring 100 being connected to a second ring 110 by at least one connecting part, in the embodiment, helical fiber 120. In the embodiment shown, there are actually three helical fibers shown as 120, 121 and 122. It may be possible to carry out this pumping operation

with as few as two helical fibers, or more fibers such as 4, 5, 6 or any number of fibers can be used.

[0012] The rings are rotated relative to one another, e.g., ring 110 is rotated in the direction shown as 111. The twisting of the rings results in a deviation of the helical fibers from their original angles and orientations. Those original angles, shown as alpha, can vary between zero and 90°. The movement reduces the distance between the rings 110 and 120, to cause contraction of the helical fibers. This contraction, in turn, causes the rings 110 to displace by an amount 140 shown in FIG. 1b. The contraction reduces the size of an ellipsoidal area defined between the rings. The ellipsoidal area is shown as 150 in FIG. 1a, and a smaller ellipsoidal area shown as 151 in FIG. 1b. By reducing this area, the area is caused to hold a smaller amount of fluid. This reduction in area and/or volume can be exploited to cause a pumping effect.

[0013] The helical elements 120, 121, 122 can be either helical fibers or helical rings, or any devices which attempt to retain their specified shape. They can be formed of shape memory alloy materials such as nitinol, or other metals, composite materials, or any material of any type which attempts to maintain a shape. The framework, e.g., the rings and other parts that hold the shape, can be a molded material, formed of a soft elastic materials such as silicone, soft rubber, or Gore-Tex.

[0014] In operation, twisting either rings or both rings causes the ellipsoidal chamber 151 to collapse. Untwisting or twisting in the opposite direction causes the chamber to expand.

[0015] The pressure difference between twisted and untwisted positions can be changed by changing the size of the rings, the lengths of the helical fibers and degree of twist of the fiber. A shroud or other type material may be placed to cover the ellipsoidal chamber 151. For example, a mesh material can be used to cover the chamber, or a material which allows less fluid leakage than a mesh, e.g., a plastic. Alternatively, no covering is necessary.

[0016] FIG. 2 illustrates how the rings 100, 110 can be twisted. In the FIG. 2 embodiment, each of the rings such as 110 includes spokes 200, which guides the rings relative to a central shaft 210. A motor 220 rotates the rings relative to the shaft. There may be two motors 220, 230 as shown, or only a single motor rotating a single ring. Alternatively, the motor can be a central motor such as shown as 240 which attaches to both rings and rotates both of the rings in alternate directions. The motor may alternatively rotate the rings in the same direction, but at different rates.

[0017] Alternative techniques of moving the rings relative to one another may also be used. Contractile action of memory metal may be actuated from a distance. Piezo actuators, shown as 241, may be associated with the memory metals. Any other technique of imposing tensile or compressive forces along the helical fibers may alternatively be used.

[0018] According to another embodiment, a magnet may be used to push or pull the fibers, forcing the rings to rotate because of the helically arranged fibers.

[0019] However the motion is induced, an oscillatory action which is formed in a periodic manner can generate force caused by the pushing and/or pulling of fluid inside the chamber 150.

[0020] In another embodiment, the device can be used as a valve. FIG. 3 illustrates the device 301, placed inside a vessel 300 as shown in FIG. 3. A pump 310, which may be a pump of FIG. 1 a, or any other kind of pump, may be used. The

device **301** may be used as a valve or pincher, to close the vessel **300**, when needed. A controller **320**, for example, may control the valve **301** to open during a time that the pump **310** is pumping in the desired direction. The valve **301** may then be closed while the pump recovers its original position. For example, when the pump **310** is a FIG. 1 device, the valve **301** is opened when the pump is in the FIG. 1A position, and closed when the pump is in the FIG. 1B position. This allows the fluid to flow in a single direction. This causes unidirectional flow in a single direction.

**[0021]** In operation, this pump can be used to mimic cardiac ventricle action using the one-way valve embodiment for providing a unidirectional flow.

**[0022]** The mechanism can easily be reversed by reversing times when the valves are closed. This technique can also be used for increasing or decreasing pressure inside cardiac chambers within isovolumic phases of a cardiac cycle to cause entrance or discharge of fluid from the chamber. The entry or discharge of the fluid can also be delayed using controlled valving action, using an inertial delay, or by the opposing elastic forces of the helical bands or the chamber itself.

**[0023]** The amount of the valving effect may also be adjustable. A pressure variation can be produced by twisting the rings while maintaining the same axial distance between the rings. This causes the helical element to buckle under pressure inward or outward. This can be used as a technique for changing the volume of the chamber, or changing the amount of constriction of the chamber.

**[0024]** Another embodiment uses these techniques in pulsatile actuation of vessels for peristaltic pumps or impedance pumps. A localized reduction of cross-sectional area is used. In this embodiment, a vessel can pass between the opening sections of the rings as shown in FIGS. 3.

**[0025]** FIGS. 4a-6B shows an embodiment where the rings are manipulated to cause the connecting fibers to form a concentric contraction. The distance between the rings are fixed, for example by holding them on one or more axes. The rings are then rotated relative to one another, while the relative angle between the rings is fixed. Alternatively, the rings may be changed in orientation. This allows the device to be used as an in-line valve relative to an encased cylindrical vessel.

**[0026]** FIGS. 4A and 4B illustrate how the device **410** encases cylindrical vessel **410** and changes the opening area of the vessel **410**. In the relaxed position, the fibers **415** surround the vessel but cause substantially no constriction of the vessel. However, when the fibers are stressed as shown in FIG. 4B, the fiber **415** restricts the internal vessel, causing constriction of the area of the vessel. FIGS. 4A and 4B show only one fiber in order to maintain clarity, but it should be understood that multiple fibers having a similar situation can be used.

**[0027]** FIGS. 4A and 4B illustrate the embodiment where the distance between the rings is expanded. FIGS. 5A and 5B illustrate the opposite situation where the distance between the rings is shortened, still causing a constriction of the fiber. In the embodiment of FIGS. 6A and 6B, the relative angle between the fibers is changed in order, to constrict the area. Any of these techniques may be combined to obtain a similar result.

**[0028]** While the above shows how the helical fibers can be moved for the valving embodiment, it should be understood

that these helical fibers can also be used in a pumping embodiment using similar movement of the ring structures relative to one another.

**[0029]** This technique can function as an actuator for pumping fluid such as in an impedance pump or peristaltic pump, or can function as a means for selectively sustaining a circumferential pressure around a vessel or Rod.

**[0030]** The general structure and techniques, and more specific embodiments which can be used to effect different ways of carrying out the more general goals are described herein.

**[0031]** Although only a few embodiments have been disclosed in detail above, other embodiments are possible and the inventor (s) intend these to be encompassed within this specification. The specification describes specific examples to accomplish a more general goal that may be accomplished in another way. This disclosure is intended to be exemplary, and the claims are intended to cover any modification or alternative which might be predictable to a person having ordinary skill in the art. For example, the rings can be of any shape, e.g., elliptical or rectangular.

**[0032]** Also, the inventor(s) intend that only those claims which use the words "means for" are intended to be interpreted under 35 USC 112, sixth paragraph. Moreover, no limitations from the specification are intended to be read into any claims, unless those limitations are expressly included in the claims.

**[0033]** The controller described herein may be any kind of computer, either general purpose, or some specific purpose computer such as a workstation. The computer may be a Pentium class computer, running Windows XP or Linux, or may be a Macintosh computer. The programs may be written in C, or Java, or any other programming language. The programs may be resident on a storage medium, e.g., magnetic or optical, e.g. the computer hard drive, a removable disk or other removable medium. The programs may also be run over a network, for example, with a server or other machine sending signals to the local machine, which allows the local machine to carry out the operations described herein.

1. A fluid-characteristic changing structure, comprising: first and second structures, at least one of which is movable relative to the other; and a plurality of spring-biased connecting parts, connecting said first and second structures, moving to change a fluidic characteristic of a chamber defined between said connecting parts.
2. A structure as in claim 1, wherein said at least one of said first and second structures are rotatable relative to the other.
3. A structure as in claim 1, wherein said at least one of said first and second structures are movable in an axial direction, which extends between said structures, relative to the other.
4. A structure as in claim 1, wherein said at least one of said first and second structures are tiltable relative to the other.
5. A structure as in claim 1, wherein said spring biased connecting parts cause a fluid pump operation as said change in fluidic characteristic.
6. A structure as in claim 1, wherein said spring biased connecting parts, cause an operation that reduces a size of a fluidic conduit as said change in fluidic characteristic.
7. A structure as in claim 1, wherein said spring biased connecting parts are helical materials.
8. A structure as in claim 7, wherein said spring biased connecting parts are connected between said first and second structures, wherein said first and second structures are substantially round, and a combination of said spring biased

connecting parts and said first and second structures form an elliptical chamber, and wherein movement of said first and second structures changes the shape of said elliptical chamber to pump a fluid that is within said elliptical chamber.

**9.** A structure as in claim **8**, wherein said helical materials are materials from the group consisting of helical fibers, helical rings, or helical bands.

**10.** A structure as in claim **8**, further comprising at least one motor, which rotates at least one of said first and second structures relative to the other.

**11.** A structure as in claim **8**, further comprising at least one actuator which actuates to change at least one of tensile or compressive forces along the helical materials.

**12.** A structure as in claim **8**, further comprising third and fourth structures, movable relative to one another, and a plurality of spring based connecting parts connecting said third and fourth structures, collectively forming a valve, said valve being actuated in synchronization with changing of the shape of said elliptical chamber.

**13-20.** (canceled)

**21.** An apparatus, comprising:  
first and second substantially ring-shaped structures;  
a plurality of helical connecting parts, connecting between said first and second substantially ring shaped structures; and

an actuating part, which is actuated to change an orientation of said first and second ring-shaped structures to cause a change in fluidic characteristic.

**22.** An apparatus as in claim **21**, wherein said actuating part changes a volume of the chamber to cause a pumping effect as said changing fluidic characteristic.

**23.** An apparatus as in claim **21**, wherein said actuating part changes a fluidic cross-section of a conduit as said change in fluidic characteristic.

**24.** An apparatus as in claim **21**, wherein said apparatus is installed in a body cavity to use for blood flow.

\* \* \* \* \*